

2011 Super Late Model updated 3/17/11



RULEBOOK DISCLAIMER: The following guidelines are recommended for UFO events and each track will be responsible for their interpretation, implementation and any necessary variance of the rules and procedures and the final result of their own racing program. The rules and/or regulations set forth herein are designed to provide for the orderly conduct of racing events and to establish minimum acceptable requirements for such events. By participating in these events, all participants are deemed to have complied with these rules as interpreted by each speedway for their event(s). **NO EXPRESSED OR IMPLIED WARRANTY OR SAFETY SHALL RESULT FROM PUBLICATIONS OF OR COMPLIANCE WITH THESE RULES AND/OR REGULATIONS.** The rules are intended as a guideline for the conduct and technical measurements of the sport and are in no way a guarantee against any degree of injury to a participant, spectator or official. The track officials shall be empowered to permit reasonable and appropriate deviations from any of the specifications herein or impose any further restrictions that in their opinion do not alter the minimum acceptable requirements. **NO EXPRESSED OR IMPLIED WARRANTY OF SAFETY SHALL RESULT FROM SUCH ALTERATION OF SPECIFICATIONS.** Any interpretation or deviation of these rules is at the discretion of the officials. Their decision is final.

All cars must have wrecker hookup. All cars should have 5 pound minimum fire extinguisher in reach of driver. All drivers should wear flame retardant fire suit, shoes and gloves. Window nets are highly recommended for all cars. No radios, communication equipment or mirrors permitted, including pit boards. No computer controlled equipment.

1. MOTOR

V8 motors only. Motor must be based on factory design and naturally aspirated. 1 spark plug and 2 valves per cylinder. No fuel injection, turbo chargers or blowers. 6" maximum setback measured from the center of the ball joint to the center of the left front spark plug OR 25 1/2" maximum setback measured from the center of the ball joint to the front of the motor plate.

Unlimited 2,250 weight—Aluminum block and heads—OK. Unlimited motor displacement.

Steel Block 2,200 weight—Steel block only. Aluminum heads—OK. Unlimited motor displacement

Spec 2,200 weight—360 ci limit. 3.480 stroke. 2.100 minimum rod pins. No titanium crankshafts, connecting rods or valves. Titanium retainers—OK. No intake modifications! 60 cc minimum head combustion chambers for all heads. No modifications to heads except intake opening may be ground or polished maximum 3/4" or into the port no farther than the closest letter of the SUPR/PPMS logo. Intake port polishing allowed maximum 1 1/2" below the bottom of the original seat ring on the back side of the bowl area and maximum 1" on the short side. Polishing allowed ONLY in the combustion chamber area to avoid hot spot chafing and in the exhaust ports as long as SUPR/PPMS logo is not affected. Valve angle may not be modified. Intake opening may not be larger than original opening. NO intake or exhaust port relocation, raising, reshaping or size modification of any kind!

Flat top or inverted pistons only. Block must be cast iron. GM 350 block. Brodix #11SPXPMS or #SUPR heads and Brodix #HV1000 intake. No Bowtie blocks. Ford 351W or 351W Sportsman block with Brodix #T1FSTDx-PMS or #SUPR heads and Victor Jr #2980 intake. No 302 Ford blocks. Chrysler 360 block with Brodix #B1BA-PMS or #SUPR heads and Victor Jr #2915 intake.

GM CT525 2,150 weight—GM CT525 crate motor part #19171821. 10.7:1 maximum compression ratio for GM CT525 motor. GM CT525 motor must be purchased from an authorized dealer and MUST remain sealed at all times. GM factory encrypted bolts cannot be altered, removed or changed. Absolutely no modification of any internal engine part. Breather system and valve cover MAY be modified. All other motor parts included with the motor as shipped from GM must remain OEM and may NOT be modified including valve springs, push rods, harmonic balancers, rocker arms etc. No machine work permitted. GM part number may not be removed from any part. Any motor modification will result in one year suspension and loss of all points and winnings. Any GM bolts that have been copied are considered trademark infringement and will be reported to the manufacturer for legal proceedings. All motor parts must be same parts listed in GM book part #88958668. Wet sump only.

GM crate motors may NOT be unsealed and may NOT be rebuilt without track approval before the rebuild. If permitted, the motor must be rebuilt at a track-authorized motor builder. Motors that are torn down for track tech must be reassembled with all of the exact same parts at the time of tear down except those that are determined by the tech official to be damaged by the tear down process. Any tear-down damaged part must be replaced with the exact same GM part. Reassembled motor must be inspected and resealed by authorized tech center BEFORE further competition. By using a GM crate motor in competition, the race team acknowledges all responsibility for the legality of the motor upon inspection at any event regardless of any previous motor verification.

2. CARBURETOR

One 2 or 4 barrel carburetor permitted.

3. FUEL

Gasoline or alcohol allowed. E-85—OK. No nitrous oxide, nitro-methane or propylene oxide. No electric fuel pumps or pressurized fuel systems. Mechanical or belt-driven fuel pumps only. Fuel lines should not pass through driver's compartment.

4. DISTRIBUTOR

Magnetos permitted.

5. EXHAUST

Headers permitted. Exhaust pipes may NOT point towards ground. Mufflers are HIGHLY recommended for all cars.

6. STARTER AND BATTERY

All cars must be self starting. Failure to start during a race will result in disqualification. Battery should be located in a safe area and covered with a metal fireproof box. Battery should not be in driver compartment. Battery disconnect kill switch to shut down motor highly recommended mounted in reach of driver and should be clearly labeled for safety crew.

2011 Super Late Model



7. REAR AXLE

Any rear end permitted. Quick change—OK

8. TRANSMISSION AND DRIVE SHAFT

Any transmission permitted. Standard transmission must have operational clutch. No in and out boxes. Transmission should be bolted to the motor and must have working reverse gear. Only one drive shaft permitted. All drive shafts should be painted white and should be surrounded by two 3" steel safety loops or sling mounted to frame.

9. TRACTION CONTROL

All traction control devices using wheel sensors are NOT permitted. Adjustable ping control devices, dial a chip controls, timing controls or automated throttle controls are NOT allowed in the cockpit or any other location accessible by driver. Any remote control components or data acquisition equipment are NOT permitted.

10. TIRES

11" maximum tire treadwidth. 16 3/4" maximum cross section with no tolerance! Tire hoop must fit freely over tire. 93" maximum circumference. Tires must have all manufacturer's stamps intact. Any brand tire permitted. Minimum tire hardness TBA before and after race at specified events. Track durometer is the official measuring tool of tire hardness regardless of stamped compound.

11. WHEELS

14" maximum steel, aluminum, carbon fiber or plastic wheels only. Wheels must be held on by bolt-type lug nuts, no knock-off type mounting permitted. 90" maximum outside width at wheels with wheels pointed straight.

12. SUSPENSION

No straight front axles. Any type steel or aluminum shocks allowed. Coilovers—OK. Suspension must be mechanical—no computer or electronic components. No titanium suspension or chassis components.

13. BRAKES

All cars must have 4 wheel braking system. No titanium or carbon fiber rotors permitted.

14. BODY

All Cars—Body must meet all specifications listed on diagram. Super late model type, full bodied cars only. All body panels must be solid—no holes, gaps, slots etc. Body line must be a flowing line from front to rear. 38" maximum front fender and door height. 48" maximum rear quarterpanel length measured from center of rear wheel. Ground clearance should be 3" minimum. Wheel clearance should be 2" minimum. No ridges, fins or raised edges on body except roof bead rolls. 40" maximum deck height at rear at all points regardless of tilted angle of body, WITH NO TOLERANCE!

Fenders must be level from side to side. Quarterpanels must be same length and cannot extend higher than rear deck. Rear deck must be level 20" forward from rear of quarterpanel and must extend between quarterpanels. Rear deck may not extend past quarterpanel and top to bottom of quarterpanel must extend to rear of deck. Quarterpanels and doors may not dish inward. Skirting may not extend behind quarterpanel. Left rear quarterpanel must extend downward from deck minimum 33" with plastic skirt at all points. Right rear quarterpanel must extend down from deck minimum of 31" with plastic skirt or 27" without plastic skirt at all points.

76" maximum body width at top deck. 82" maximum body width at bottom of doors measured at the center of the car. 86" maximum width at rear of quarterpanels from bottom to 19" from ground. All body width variations must taper evenly on both sides.

All fenders, doors and quarterpanels should roll inward 1/2" to 1" at top, with sides over upper body. No sharp or jagged edges, fasteners, etc. No wings or tunnels permitted under body or chassis. Unapproved bodies may be assessed a 50 pound weight penalty.

15. SPOILERS

Spoiler and spillboard dimensions may be adjusted during the season for competition or vary due to track size.

Spoiler and braces must meet all specifications listed on diagram. 72" maximum width. Maximum 3 solid side spoilers permitted. Side spoilers must be mounted at rear of deck and outer side spoilers must be at outside edge of deck. Side spoiler must taper down evenly from maximum to minimum height and may be rounded or triangular in shape. Side spoilers must be mounted at rear of quarterpanels. 2 additional 1" open aluminum braces permitted. Spoiler should be clear lexan or aluminum. No driver-adjustable spoilers. No other spoilers or wings.

Unlimited 2,250 weight and Steel Block 2,200 weight—8" rear spoiler height measured from the top of rear deck and 8" maximum spoiler length measured at angle of spoiler. 8" maximum side spoiler height from rear of side spoiler to 6" forward or rear of side spoiler. 4.5" maximum height at front of side spoiler. 18" maximum total side spoiler length. Spoiler must be mounted at rear of deck and cannot be suspended to create a wing effect.

Spec 2,200 weight—12" rear spoiler height measured from the top of rear deck and 12" maximum spoiler length measured at angle of spoiler. 12" maximum side spoiler height from rear of side spoiler to 10" forward or rear of side spoiler. 4.5" maximum height at front of side spoiler. 24" maximum total side spoiler length. Spoiler must be mounted at rear of deck and cannot be suspended to create a wing effect.

Spec motor cars permitted 1 maximum 4" high x 32" long spillboard mounted on the nose. Spillboard may have 1" ridge running at 90 degree angle on top. Spillboard measured at mounted angle. No other ridges are allowed on the nose.

GM CT525 2,150 weight—12" rear spoiler height measured from the top of rear deck and 14" maximum spoiler length measured at angle of spoiler. 14" maximum side spoiler height from rear of side spoiler to 14" forward of rear of side spoiler. 6" maximum height at front of side spoiler. 28" maximum total side spoiler length. GM CT525 motor cars permitted 1 maximum 4" high x 36" long spillboard mounted on the nose. Spillboards may have 1" ridge running at 90 degree angle on top. Spillboards measured at mounted angle. No other ridges are allowed on the nose.

2011 Super Late Model



16. NOSEPIECE, FENDER FLARES AND HOOD

Approved stock appearing molded nosepiece required and should match roof and roof supports. Nosepiece must be made of flexible material. **15"** minimum nosepiece height measured from bottom of nosepiece to where sheet metal is attached, following the angle of the nosepiece. Nose must be mounted level. Two-piece nose cannot be widened. **53"** maximum nosepiece extension measured from center of front hub with wheels turned straight. **3"** minimum ground clearance. Nosepiece may not be modified or cut. Unapproved nosepieces will be assessed a **50 to 125** pound penalty. Tech inspector may require that any unapproved nosepiece must be changed.

38" maximum front fender height from ground. Plastic front fender flares permitted, but cannot alter original shape of nosepiece and must have collapsible support (no steel supports). Fender flares may extend **1"** outside front wheels when pointed straight. **90"** maximum fender flare width. Front fender flares may extend maximum **3" above the top of fender and 4" above the sloped nosepiece panel.**

Hood must be level from side to side. Scoop may be maximum of **1"** above air cleaner. **No** raised edges on scoop.

17. ROOF

Approved roof and roof supports should match nosepiece. Minimum **44"** long x **48"** wide, maximum **54"** long x **52"** wide. **45"** minimum height from ground, **48"** maximum. Roof must be mounted near center of car, parallel to deck and level. Roofline and side panel window contours should be stock appearing and match nosepiece. Roofline **MUST** be rounded—no flat, wedge, bellied or hollow roofs.

Rear roof and front roof supports mandatory. Rear roof supports may extend **43"** from rear of driver's side window. Rear roof supports must taper downward evenly from outside edges of roof with a **2"** maximum outward bow both to the sides and rear. **17"** maximum at top of rear roof support. **10"** high x **15"** long minimum rear support window is optional and recommended for appearance. Rear support window may be filled with clear lexan. **2"** minimum front roof post width, **4"** maximum. Front roof post bracing may extend **7"** vertical and horizontal. Front roof posts must extend forward to the rear of hood. **½"** maximum bead rolls permitted on roof running from front to rear in direction, **4** maximum including edge bead rolls.

Door window opening height should be **12"** minimum measured from deck to roof. **1.5"** maximum roll down permitted along front and rear edge of roof. Roof may not turn upward. **4"** maximum hinged sun shield permitted in front of driver. **25** pound penalty for unapproved roofs.

18. FRAME

Late model, full tubing frame cars only. **103"** minimum wheelbase, **108"** maximum. All frames should be constructed of **2"x 2"** square steel tubing or **1 ¾"** outside diameter round steel tubing, with **.083"** minimum material thickness. All round tubing frame cars should use **4130** chrome molly steel or DOM in frame construction. No holes may be cut in frame. All other chassis tubing should **1 ¾"** at outside diameter and have a minimum thickness of **.083"**.

Car should have horizontal safety bar constructed from same steel tubing as frame, mounted behind fuel cell and securely welded to frame. Rear bumper should be at least **4"** behind fuel cell. Center of rear bumper and safety bar should be at rear deck center height, approximately **19"** from the ground and should be at least as wide as frame. Tubing should also extend downward to form a horizontal bar at the bottom height of the fuel cell, with additional vertical and diagonal tubing bracing the lower tubing to the rear bumper and the safety bar. Lower tubing should be at least as wide as fuel cell. No part of the fuel cell should be below the protective tubing. Any rear bumper that extends more than **8"** from rear of frame should be rounded and directed toward the front of car. Bumper should not have any sharp edges. **No** external rub rails.

19. FUEL CELL

35 gallon maximum, racing-approved fuel cell should be securely mounted inside a **20** gauge steel or **.060"** aluminum metal box and secured to frame with a minimum of two **2" x 1/8"** thick steel straps around entire fuel cell. Minimum **7/16"** bolts should be used to mount the fuel cell. The fuel pick up should be on the top or right side of the fuel cell, be constructed of steel and should have a check valve in case of roll over. Fuel cell should be mounted in square tubing frame. Fuel cell should be mounted behind the rear axle and between the rear tires, at least **4"** in front of the rear bumper. **9"** minimum fuel cell ground clearance. No part of the fuel cell may be lower than the rear end housing. Car number must be displayed on fuel cell, **6"** minimum height.

20. ROLL CAGE

4-post, box-type roll cage should be constructed of **1 ½"** minimum outside diameter and **.095** minimum material thickness steel tubing. Roll cage should have at least **3** horizontal bars at driver's side door and **2** horizontal bars at passenger side door, extended outward into door panels with **2** vertical bars between each horizontal bar as additional support. An extra vertical side brace bar is recommended on the left side in line with steering wheel. Door bars should be **1 ½"** in diameter with a minimum thickness of **.065**. Both door window areas should remain open and unblocked by roll cage bars for easy exit. Roll cage should extend forward on driver's side to protect foot area completely. Roll cage should be welded to frame in at least **6** places (in addition to diagonal bracing) and welded together at all intersecting points. Diagonal bars should brace roll cage at rear, and should run from frame to top of roll cage.

Top of roll cage should be at least **2"** above top of driver's helmet. All areas of the cockpit should have at least **11"** to **12"** of clearance below the roll cage and roof. All roll cage bars within reach of driver should be covered with non-flammable foam padding. Other than padding, roll cage must remain exposed above top of door with no aerodynamic effects. Right-side padded headrest or head net recommended attached to roll cage. Bars or wire mesh in windshield and driver's side quick-release window net highly recommended.

21. FIREWALLS AND INTERIOR

A full metal firewall constructed from **18** gauge steel or **1-1/8"** thick aluminum should be joined to seal off driver compartment at front, rear, sides and floorboard. Full metal floorboard. Top of interior may be maximum of **4"** below top of doors. The start of the dropped interior should remain closed as part of the firewall. The interior must taper up gradually to be even with the rear quarterpanel and level for **20"** from rear of deck and quarterpanel. Interior must be mounted flush with outside body panels. Interior clearance should be **11"** to **12"** minimum below roll cage at all points for easy exit. Onboard fire suppression system recommended.

2011 Super Late Model



22. SEAT AND SAFETY BELT

Metal racing-approved seat with padded headrest should be securely attached to frame. **3", 5, 6 or 7-** point, quick release racing belt with double harness should be bolted to frame or roll bars. Mounts should run in the same direction to secure the belt. **Belt should not come in contact with sharp edges.** Safety belts should be replaced if two years old, and all worn or damaged safety belts should be replaced. Quick-release, racing-type steering should be used.

23. FIRE SUIT AND HELMET

Drivers should have flame retardant firesuit and racing approved full-face helmet with face shield. Nomex shoes, socks, gloves, and hood highly recommended. Head and neck restraint system and arm restraints are highly recommended.

24. WEIGHT

Weight limits may be adjusted during the season for competition. Weight limits may vary by track or co-sanction. Verify weight limits with track!
Base weights—2,250 pound minimum weight with driver after race for Unlimited aluminum block cars. **2,200** pound minimum for Steel Block cars. **2,200** pound minimum for Spec motor cars meeting all specifications. **2,150** pound minimum for GM **CT525** motor cars. **No tolerance.** All weights should be solid material, entirely painted white or a bright color and marked with car number. Each weight should be **50** pound maximum. Weights should be bolted to frame with two ½" Grade **5** bolts on two weight clamps or secured with steel plate. **No** weights should be attached to rear bumper or in driver's area. Weights should not be lead pellets or liquid. Each weight should be bolted to the frame individually and should not be stacked on another weight. **Track** may add or deduct **50** pounds from any weight category.

2011 Super Late Model GM CT525 Tech Specs

GM CT525

Balanced	internal
Block part number	#19171821
Block type	cast-aluminum with 6 -bolt, cross-bolted main caps
Bore x stroke (in)	4.065 x 3.62 (103.25 x 92mm)
Camshaft duration (@.050 in)	226 degree intake / 236 degree exhaust
Camshaft lift (in)	.CT525 intake / .CT525 exhaust
Camshaft part number	#12480110
Camshaft type	hydraulic roller
Compression ratio	10.7:1
Connecting rod part number	#12617570
Connecting rods type	powdered metal
Crankshaft part number	#12597569
Crankshaft type	nodular iron
Cylinder head part number	#12615879
Cylinder head type	LS3 rectangle port; aluminum as-cast with 68cc chambers
Displacement (cu in)	376 cu in (6.2L)
Engine name	Circle Track CT525/CT525:
Engine type	LS Series Gen IV Small-Block V-8
Maximum rpm	6700
Piston part number	#19168089
Pistons type	hypereutectic aluminum
Recommended fuel	92 octane
Reluctor wheel	58X
Rocker arm ratio	1.7:1
Rocker arms part number	#12569167 intake / #10214664 exhaust
Rocker arms type	investment-cast, roller trunnion
Valve size (in)	2.165 intake / 1.59 exhaust

2011 Super Late Model Body Specs



All body panels must be solid - no holes, gaps, slots, etc!

Side spoiler specifications - max. 3 side spoilers.
Must taper down evenly! May be triangular or curved.

Max length at top - Unlimited 6", Spec 10", GM 525 14".

Roof supports must meet rear deck as shown.
Max. 17" at top of roof supports.

Unlimited & Spec 4.5" max.
GM 525 6" max.

Unlimited 8"
Spec 12", GM 525 14".

Max. total length - Unlimited 18", Spec 24", GM 525 28".

Spillboards may have 1" ridge running at 90 degree angle on top.
Spec - 1 spillboard, max. 4" high x 32" long,
GM 525 - 1 spillboard, max. 4" high x 36" long,
Unlimited - not permitted.

15" min. nosepiece.

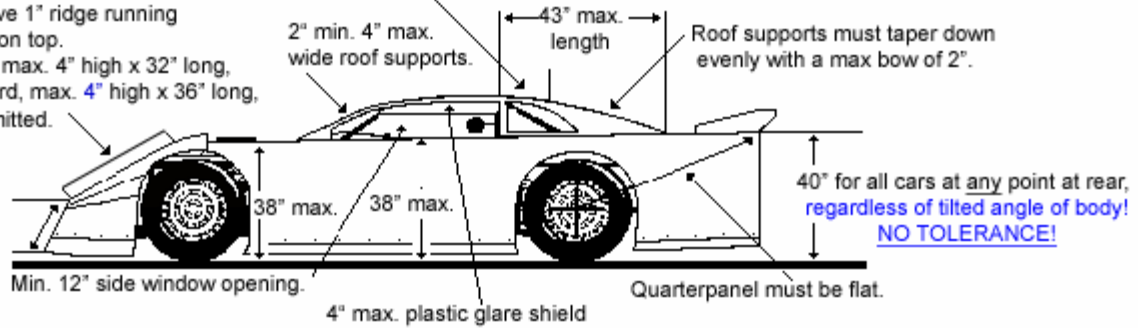

Rear deck must be parallel to the ground and even with top of quarterpanels min. of 20" forward of spoiler.

Rear support window min. 10" high x 15" long.

Max. spoiler length - Unlimited 8", Spec 12", GM 525 14".

Roofline must be rounded. No flat roofs!

Max. vertical spoiler height
Unlimited 8",
Spec & GM 525 12".

Max. 7" roof support braces in each direction up & back.

Left quarterpanel must extend down from deck min. 33" with skirt. Right quarterpanel must extend down from deck min. 31" with skirt OR 27" without skirt. Top to bottom of quarterpanel must extend to rear of deck.

Fender flares may be 3" max. higher than top of fenders and 4" max. higher than nosepiece slope.

Rear of skirt must be even with rear of quarterpanel.

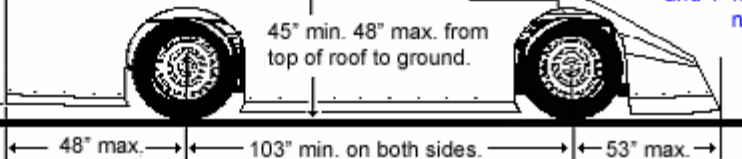

Ground clearance should be 3" minimum at all points.

Body clearance around tires should be 2" minimum at all points.

If aluminum brace is used across top of spoiler, it must be turned down and may not add to height or length of spoiler.

Unlimited - 8" max. spoiler height.
Spec - 12" max. spoiler height.
GM 525 - 12" max. spoiler height

38" max. to top of doors.
40" max. to top or rear deck.

Rear roof supports must taper down evenly with a 2" max. outward bow.

No spoilers, wings or tunnels of any kind under body or chassis.

48" max. 45" min roof height.

All spoiler braces must be same dimensions. Outside braces must be mounted even with quarterpanels.

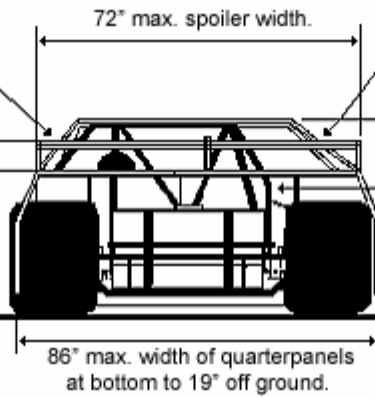

82" max. width at the bottom of the doors measured in the center of the car.

Fender flares may extend 1" max. outside of wheels with wheels pointed straight.

